

DOUBLE PIPE CLAMPS Center Mounting Hole

MATERIAL: HD Galv Steel, Per ASTM A653/A563M; CRS, Per ASTM A 1008 CS Type B
CUSHION: Black Vinyl, 1/32" Thick

FINISH: Z1 - HD Galv Steel, Chem Treated G90
 Z2 - .0002 min Zinc, Clear

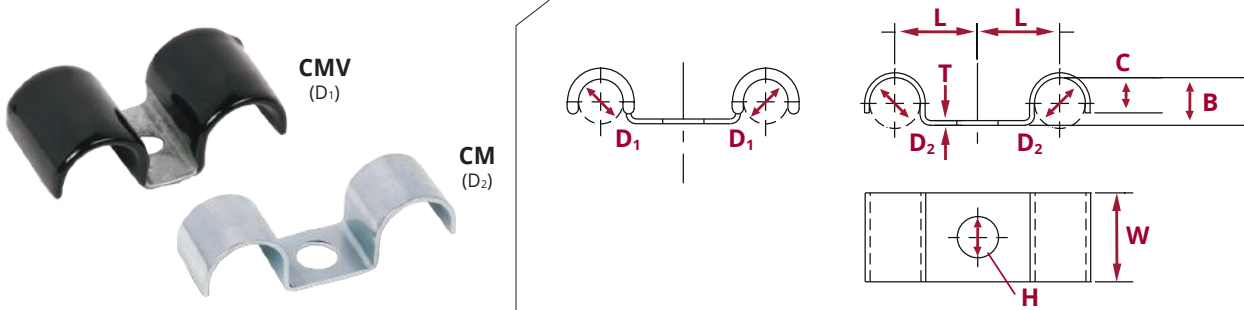

D ₁		D ₂		L	W	H	B	C	T
Clamping Diameter	Part Number	Clamping Diameter	Part Number	Center To Center	Width	Hole Diameter	Base To Top Of Radius	Ref Only Closure	Material Thickness
±.031		±.015		±.031	±.010	±.005	±.015	±.015	±.002
.375	CMV-0709	.437	CM-0709	.687	.750	.281	.375	.343	.048
	CMV-0711		CM-0711	.687	.750	.343	.375	.343	.048
.437	CMV-0809	.500	CM-0809	.812	.750	.281	.437	.250	.060
	CMV-0811		CM-0811	.812	.750	.343	.437	.250	.060
.500	CMV-0909	.562	CM-0909	.875	.750	.281	.468	.400	.060
	CMV-0911		CM-0911	.875	.750	.343	.468	.400	.060
.562	CMV-1009	.625	CM-1009	.625	.750	.281	.625	.500	.060
	CMV-1011		CM-1011	.625	.750	.343	.625	.500	.060
.625	CMV-1109	.687	CM-1109	.625	1.000	.281	.625	.437	.060
.750	CMV-1209	.687	CM-1209*	.875	.750	.281	.718	.500	.060
	CMV-1211		CM-1211*	.875	.750	.343	.718	.500	.060
	CMV-1213		CM-1213*	.875	.750	.406	.718	.500	.060

NOTE: Part numbers shown with an asterisk (*) are only available in Z2.