

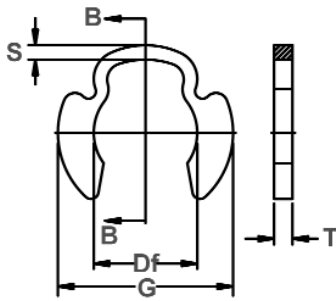

PO/POL Shaft Rings

Radially Assembled, External Poodle

The PO ring features wide "ears" (resembling those of a poodle dog, thus the name) which offer extra retention surface against the retained part. PO rings also come in thinner sizes as a standard series of rings known as POL.



Free Diameter & Ring Measurements
With Section B-B

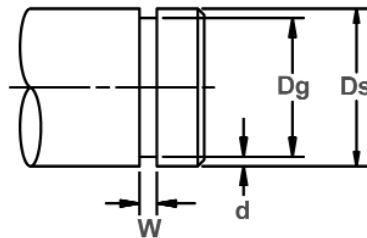

Shaft Diameter &
Groove Dimensions

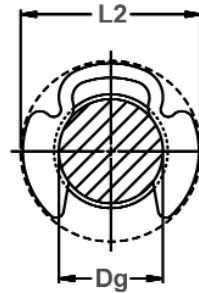

Clearance Diameter
Installed In Groove

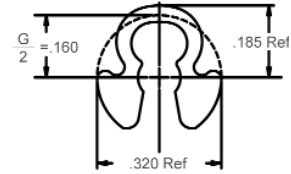

PO-15 & POL-15
Only

RING NO.	SHAFT DIAMETER			GROOVE SIZE						RING SIZE & WEIGHT				CLR. DIA. Installed in groove	i THRUST LD. (lbs.) Sqr. Corner Abutment			
				DIAMETER		WIDTH	DEPTH	FREE DIAMETER	THICKNESS***		Weight Per 1000 Pcs.	Pr	Pg					
	Ds DEC	Ds FRACT	Ds mm	Dg	Tol.	F.I.M*	W	Tol.	d ref.	Df				Tol.	T	Tol.	L2	Pr
PO-15	.156	5/32	4.0	.120	±.004	.002	.039			.018	.110		.035		.42	.39	457	110
PO-18	.188	3/16	4.8	.148	±.005	.002	.039			.020	.140	±.003	.035		.63	.42	609	130
PO-25	.250	1/4	6.4	.210		.003	.039			.020	.188		.035		.84	.52	914	200
PO-31	.312	5/16	7.9	.272	±.006	.003	.046	+ .006		.020	.250		.042	±.002	1.46	.63	1320	250
PO-37	.375	3/8	9.5	.331		.003	.046			.022	.312		.042		1.92	.72	1573	300
PO-43	.438	7/16	11.1	.390		.003	.056			.024	.375	±.004	.050		2.66	.79	2233	400
PO-50	.500	1/2	12.7	.440	±.008	.004	.056			.030	.406		.050		3.30	.89	2538	600
PO-62	.625	5/8	15.9	.531		.004	.056			.047	.500	±.005	.050		4.65	1.03	3045	1100
PO-75	.750	3/4	19.0	.632		.004	.068			.059	.594		.062		6.35	1.17	4669	1600
PO-100	1.000	1	25.4	.860	±.010	.004	.086	+ .008		.070	.812	±.006	.078	±.003	12.65	1.51	7613	2600
PO-125	1.250	1 -1/4	31.8	1.090		.006	.103			.080	1.032		.093		25.20	1.90	11165	3500
PO-150	1.500	1 -1/2	38.1	1.317		.008	.120			.091	1.250	±.008	.109		36.3	2.18	15530	4800
PO-175	1.750	1-3/4	44.4	1.480	±.015	.010	.139	+ .010		.135	1.406	±.010	.125	±.004	53.0	2.45	20808	8200
PO-200	2.000	2	50.8	1.730		.012	.139			.135	1.625	±.015	.125		69.2	2.83	23853	9450
POL-15	.156	5/32	4.0	.120	±.004	.002	.029			.018	.110		.025		.30	.39	325	110
POL-18	.188	3/16	4.8	.148	±.005	.002	.029			.020	.140		.025		.45	.42	436	130
POL-25	.250	1/4	6.4	.210		.003	.029			.020	.188		.025		.60	.52	650	200
POL-31	.312	5/16	7.9	.272	±.006	.003	.029	+ .006		.020	.250	±.003	.025	±.002	.87	.63	792	250
POL-37	.375	3/8	9.5	.331		.003	.039			.022	.312		.035		1.60	.72	1320	300
POL-43	.438	7/16	11.1	.390		.003	.039			.024	.375	±.004	.035		1.86	.79	1878	400
POL-50	.500	1/2	12.7	.440	±.008	.004	.046			.030	.406		.042		2.77	.89	2132	600
POL-62	.625	5/8	15.9	.531		.004	.046			.047	.500	±.005	.042		3.65	1.03	2538	1100
POL-75	.750	3/4	19.0	.632	±.010	.004	.056	+ .008		.059	.594		.050		5.35	1.17	3756	1600
POL-100	1.000	1	25.4	.860		.004	.056			.070	.812	±.006	.050		8.60	1.51	4872	2600

*F.I.M. (FULL INDICATOR MOVEMENT)- MAXIMUM ALLOWABLE DEVIATION OF CONCENTRICITY BETWEEN GROOVE AND SHAFT.

i BASED ON HOUSINGS/SHAFTS MADE OF COLD ROLLED STEEL. FOR AN EXPLANATION OF FORMULAS USED TO DERIVE THRUST LOAD AND OTHER PERFORMANCE DATA, CONTACT THE ROTOR CLIP ENGINEERING DEPARTMENT.

***FOR PLATED RINGS, ADD .002" TO THE LISTED MAXIMUM THICKNESS. MAXIMUM RING THICKNESS WILL BE A MINIMUM OF .0002" LESS THAN THE LISTED GROOVE WIDTH (W) MINIMUM.

NOTE: THIS GROUP CONTAINS ALTERNATE THICKNESS VALUES (COLUMN "T"). OTHER PARAMETERS SUCH AS WIDTH OF GROOVE ("W") AND THRUST LOAD "Pr" ALSO DIFFER FROM STANDARD VERSIONS. PLEASE TAKE THIS INTO CONSIDERATION WHEN SELECTING A PO RING FOR YOUR DESIGN.

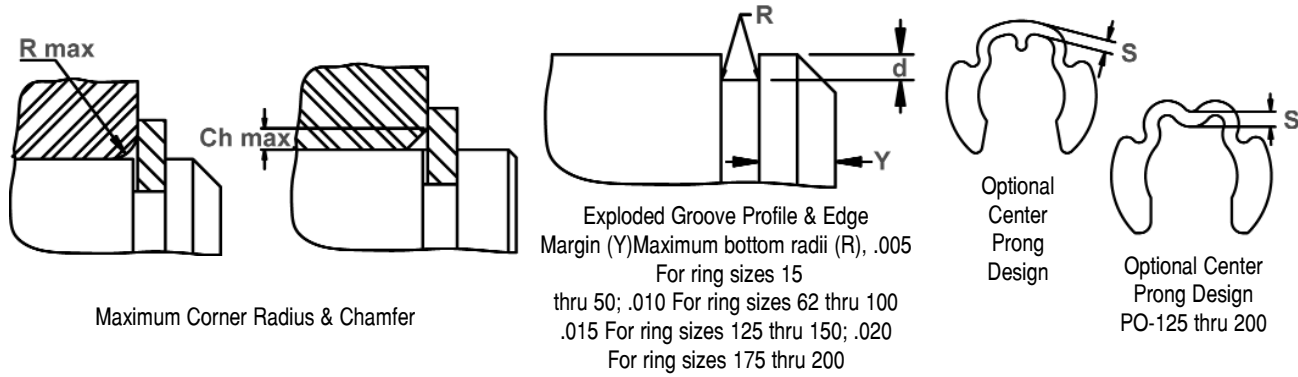

Maximum Corner Radius & Chamfer

RING NO.	OUTSIDE DIA.	LARGE SECT.	ALLOWABLE CORNER RADII & CHAMFERS		MAX LOAD W/ R max or Ch max in (lbs.)	EDGE MARGIN	R.P.M. LIMITS Steel Rings
			G ref.	S			
PO-15	.320	.042	.050	.040	250	.036	80000
PO-18	.400	.048	.050	.040	270	.040	80000
PO-25	.482	.058	.050	.040	310	.040	65000
PO-31	.588	.074	.065	.050	400	.040	65000
PO-37	.680	.081	.065	.050	430	.044	65000
PO-43	.752	.081	.080	.060	600	.048	60000
PO-50	.826	.097	.080	.060	630	.060	50000
PO-62	.966	.086	.080	.060	720	.094	45000
PO-75	1.095	.095	.085	.065	1000	.118	38000
PO-100	1.415	.113	.090	.065	1800	.140	25000
PO-125	1.800	.180	.090	.065	2750	.160	11000
PO-150	2.050	.208	.10	.07	3800	.182	9000
PO-175	2.300	.235	.12	.09	5100	.270	7000
PO-200	2.650	.250	.13	.10	5100	.270	5000
POL-15	**	.042	.050	.040	130	.036	80000
POL-18	.400	.048	.050	.040	140	.040	80000
POL-25	.482	.058	.050	.040	150	.040	65000
POL-31	.588	.074	.050	.040	150	.040	65000
POL-37	.680	.081	.065	.050	200	.044	65000
POL-43	.752	.081	.065	.050	300	.048	60000
POL-50	.826	.097	.080	.060	450	.060	50000
POL-62	.966	.086	.080	.060	500	.094	45000
POL-75	1.095	.095	.090	.070	650	.118	38000
POL-100	1.415	.113	.090	.070	740	.140	25000

LARGER SIZES MAY BE AVAILABLE UPON REQUEST.

SEE NOTE ON PREVIOUS PAGE.

HARDNESS RANGES: STAINLESS STEEL RINGS (PH 15-7MO)

RING TYPE	SIZE RANGE	SCALE	ROCKWELL HARDNESS
PO	All	C	44-51

HARDNESS RANGES: BERYLLIUM COPPER RINGS

RING TYPE	SIZE RANGE	SCALE	ROCKWELL HARDNESS
PO	15-25	30N	54-62
	31+	C	34-43

HARDNESS RANGES: CARBON STEEL RINGS (SAE 1060-1090)

RING TYPE	SIZE RANGE	SCALE	ROCKWELL HARDNESS
PO	All	C	47-53

HARDNESS RANGES: STAINLESS STEEL RINGS (PH 15-7MO)

RING TYPE	SIZE RANGE	SCALE	ROCKWELL HARDNESS
POL	15-31	30N	63-69.5
	37+	C	44-51

HARDNESS RANGES: BERYLLIUM COPPER RINGS

RING TYPE	SIZE RANGE	SCALE	ROCKWELL HARDNESS
POL	15-43	30N	54-62
	50+	C	34-43

HARDNESS RANGES: CARBON STEEL RINGS (SAE 1060-1090)

RING TYPE	SIZE RANGE	SCALE	ROCKWELL HARDNESS
POL	15-31	30N	65.5-71
	37+	C	47-53

