

WIRING AND TUBE CLAMPS Closed Type – Furnished Open

MATERIAL: HD Galv Steel, Chem-Treated G90, Per ASTM A653/A653M

CUSHION: Black Vinyl, 1/32" Thick

COV-CO: Parts Have One Round and One Slotted Hole

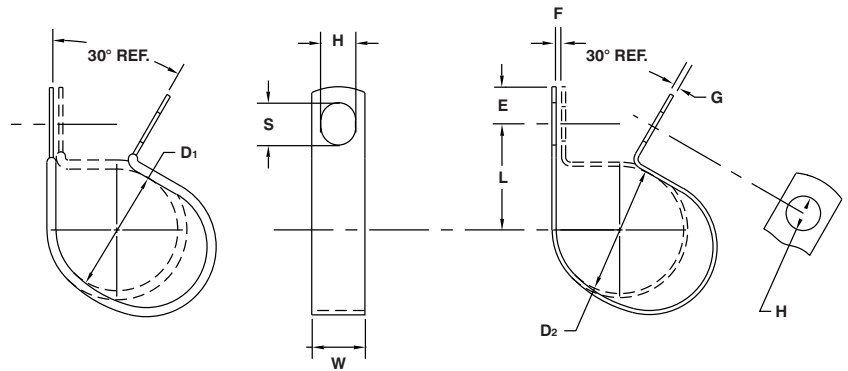

D ₁	Part Number	D ₂	Part Number	H	L	W	E	F	G	S
Clamping Diameter		Clamping Diameter		Hole Diameter	Center To Center	Width	Hole Center To End	Gap	Gage	Slot Length
±.031		±.015		±.005	±.031	±.010	±.015	±.031	See Pg. 40	±.020
		.125	CO-0209	.281	.468	.500	.312	.031	.032	.375
			CO-0211	.343	.531	.625	.375	.031	.032	.437
			CO-0213	.406	.593	.750	.437	.031	.032	.500
.125	COV-0309	.187	CO-0309	.281	.468	.500	.312	.031	.032	.375
	COV-0311		CO-0311	.343	.531	.625	.375	.031	.032	.437
	COV-0313		CO-0313	.406	.593	.750	.437	.031	.032	.500
.187	COV-0409	.250	CO-0409	.281	.500	.500	.312	.031	.032	.375
	COV-0411		CO-0411	.343	.562	.625	.375	.031	.032	.437
	COV-0413		CO-0413	.406	.625	.750	.437	.031	.032	.500
	COV-0415		CO-0415	.468	.687	.750	.500	.031	.032	.562
.250	COV-0509	.312	CO-0509	.281	.531	.500	.312	.031	.032	.375
	COV-0511		CO-0511	.343	.593	.625	.375	.031	.032	.437
	COV-0513		CO-0513	.406	.656	.750	.437	.031	.032	.500
	COV-0515		CO-0515	.468	.718	.750	.500	.031	.032	.562
	COV-0517		CO-0517	.531	.781	.875	.562	.031	.032	.625
.312	COV-0609	.375	CO-0609	.281	.562	.500	.312	.031	.032	.375
	COV-0611		CO-0611	.343	.625	.625	.375	.031	.032	.437
	COV-0613		CO-0613	.406	.687	.750	.437	.031	.032	.500
	COV-0615		CO-0615	.468	.750	.750	.500	.031	.032	.562
	COV-0617		CO-0617	.531	.812	.875	.562	.031	.032	.625
.375	COV-0709	.437	CO-0709	.281	.593	.500	.312	.062	.032	.375
	COV-0711		CO-0711	.343	.656	.625	.375	.062	.032	.437
	COV-0713		CO-0713	.406	.718	.750	.437	.062	.032	.500
	COV-0715		CO-0715	.468	.781	.875	.500	.062	.032	.562
	COV-0717		CO-0717	.531	.843	.875	.562	.062	.032	.625
.437	COV-0809	.500	CO-0809	.281	.625	.500	.312	.062	.048	.375
	COV-0811		CO-0811	.343	.687	.625	.375	.062	.048	.437
	COV-0813		CO-0813	.406	.750	.750	.437	.062	.048	.500
	COV-0815		CO-0815	.468	.812	.875	.500	.062	.048	.562
	COV-0817		CO-0817	.531	.875	1.000	.562	.062	.048	.625
.500	COV-0909	.562	CO-0909	.281	.656	.500	.312	.062	.048	.375
	COV-0911		CO-0911	.343	.718	.625	.375	.062	.048	.437
	COV-0913		CO-0913	.406	.781	.750	.437	.062	.048	.500
	COV-0915		CO-0915	.468	.843	.875	.500	.062	.048	.562
	COV-0917		CO-0917	.531	.906	1.000	.562	.062	.048	.625
.562	COV-1009	.625	CO-1009	.281	.687	.500	.312	.062	.048	.375
	COV-1011		CO-1011	.343	.750	.625	.375	.062	.048	.437
	COV-1013		CO-1013	.406	.812	.750	.437	.062	.048	.500
	COV-1015		CO-1015	.468	.875	.875	.500	.062	.048	.562
	COV-1017		CO-1017	.531	.937	1.000	.562	.062	.048	.625

Except for clamping diameter, dimensions of cushioned and plain parts are identical.
 NOTE: Part numbers shown with asterisk (*) are produced from CRCQ Steel, Zinc Plated.

WIRING AND TUBE CLAMPS Closed Type – Furnished Open

MATERIAL: HD Galv Steel, Chem-Treated G90, Per ASTM A653/A653M

CUSHION: Black Vinyl, 1/32" Thick

COV-CO: Parts Have One Round and One Slotted Hole

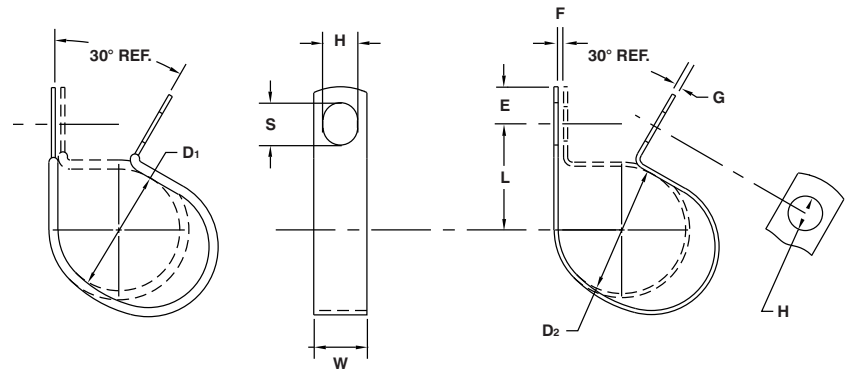

D ₁	Part Number	D ₂	Part Number	H	L	W	E	F	G	S
Clamping Diameter		Clamping Diameter		Hole Diameter	Center To Center	Width	Hole Center To End	Gap	Gage	Slot Length
±.031		±.015		±.005	±.031	±.010	±.015	±.031	See Pg. 40	±.020
.625	COV-1109	.687	CO-1109	.281	.718	.500	.312	.062	.048	.375
	COV-1111		CO-1111	.343	.781	.625	.375	.062	.048	.437
	COV-1113		CO-1113	.406	.843	.750	.437	.062	.048	.500
	COV-1115		CO-1115	.468	.906	.875	.500	.062	.048	.562
	COV-1117		CO-1117	.531	.968	1.000	.562	.062	.048	.625
.687	COV-1209	.750	CO-1209	.281	.750	.500	.312	.062	.048	.375
	COV-1211		CO-1211	.343	.812	.625	.375	.062	.048	.437
	COV-1213		CO-1213	.406	.875	.750	.437	.062	.048	.500
	COV-1215		CO-1215	.468	.937	.875	.500	.062	.048	.562
	COV-1217		CO-1217	.531	1.000	1.000	.562	.062	.048	.625
.750	COV-1309	.812	CO-1309	.281	.781	.500	.312	.062	.048	.375
	COV-1311		CO-1311	.343	.843	.625	.375	.062	.048	.437
	COV-1313		CO-1313	.406	.906	.750	.437	.062	.048	.500
	COV-1315		CO-1315	.468	.968	.875	.500	.062	.048	.562
	COV-1317		CO-1317	.531	1.031	1.000	.562	.062	.048	.625
.812	COV-1409	.875	CO-1409	.281	.812	.500	.312	.062	.048	.375
	COV-1411		CO-1411	.343	.875	.625	.375	.062	.048	.437
	COV-1413		CO-1413	.406	.937	.750	.437	.062	.048	.500
	COV-1415		CO-1415	.468	1.000	.875	.500	.062	.048	.562
	COV-1417		CO-1417	.531	1.062	1.000	.562	.062	.048	.625
.875	COV-1509	.937	CO-1509	.281	.843	.500	.312	.062	.048	.375
	COV-1511		CO-1511	.343	.906	.625	.375	.062	.048	.437
	COV-1513		CO-1513	.406	.968	.750	.437	.062	.048	.500
	COV-1515		CO-1515	.468	1.031	.875	.500	.062	.048	.562
	COV-1517		CO-1517	.531	1.093	1.000	.562	.062	.048	.625

Except for clamping diameter, dimensions of cushioned and plain parts are identical.
 NOTE: Part numbers shown with asterisk (*) are produced from CRCQ Steel, Zinc Plated.

WIRING AND TUBE CLAMPS Closed Type – Furnished Open

MATERIAL: HD Galv Steel, Chem-Treated G90, Per ASTM A653/A653M

CUSHION: Black Vinyl, 1/32" Thick

COV-CO: Parts Have One Round and One Slotted Hole

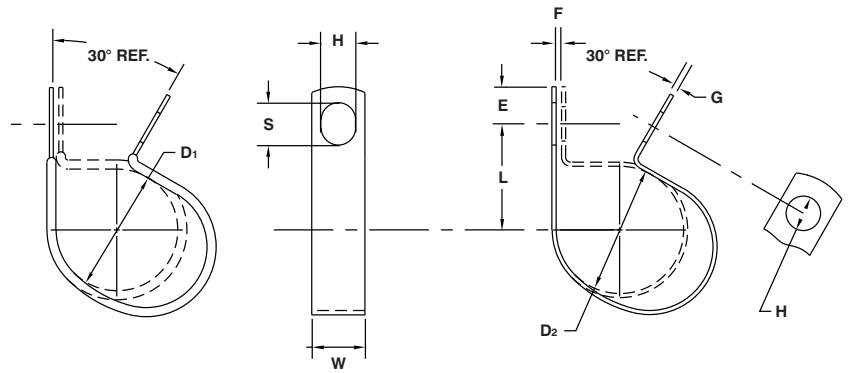

D ₁		D ₂		H	L	W	E	F	G	S
Clamping Diameter	Part Number	Clamping Diameter	Part Number	Hole Diameter	Center To Center	Width	Hole Center To End	Gap	Gage	Slot Length
±.031		±.015		±.005	±.031	±.010	±.015	±.031	See Pg. 40	±.020
.937	COV-1609	1.000	CO-1609	.281	.875	.500	.312	.062	.048	.375
	COV-1611		CO-1611	.343	.937	.625	.375	.062	.048	.437
	COV-1613		CO-1613	.406	1.000	.750	.437	.062	.048	.500
	COV-1615		CO-1615	.468	1.062	.875	.500	.062	.048	.562
	COV-1617		CO-1617	.531	1.125	1.000	.562	.062	.048	.625
1.000	COV-1709	1.062	CO-1709	.281	.906	.500	.312	.062	.048	.375
	COV-1711		CO-1711	.343	.968	.625	.375	.062	.048	.437
	COV-1713		CO-1713	.406	1.031	.750	.437	.062	.048	.500
	COV-1715		CO-1715	.468	1.093	.875	.500	.062	.048	.562
	COV-1717		CO-1717	.531	1.156	1.000	.562	.062	.048	.625
1.062	COV-1809	1.125	CO-1809	.281	.937	.500	.312	.062	.048	.375
	COV-1811		CO-1811	.343	1.000	.625	.375	.062	.048	.437
	COV-1813		CO-1813	.406	1.062	.750	.437	.062	.048	.500
	COV-1815		CO-1815	.468	1.125	.875	.500	.062	.048	.562
	COV-1817		CO-1817	.531	1.187	1.000	.562	.062	.048	.625
1.125	COV-1909	1.187	CO-1909	.281	.968	.500	.312	.062	.048	.375
	COV-1911		CO-1911	.343	1.031	.625	.375	.062	.048	.437
	COV-1913		CO-1913	.406	1.093	.750	.437	.062	.048	.500
	COV-1915		CO-1915	.468	1.156	.875	.500	.062	.048	.562
	COV-1917		CO-1917	.531	1.218	1.000	.562	.062	.048	.625
1.187	COV-2009	1.250	CO-2009	.281	1.000	.500	.312	.062	.048	.375
	COV-2011		CO-2011	.343	1.062	.625	.375	.062	.048	.437
	COV-2013		CO-2013	.406	1.125	.750	.437	.062	.048	.500
	COV-2015		CO-2015	.468	1.187	.875	.500	.062	.048	.562
	COV-2017		CO-2017	.531	1.250	1.000	.562	.062	.048	.625
1.250	COV-2109	1.312	CO-2109	.281	1.031	.500	.312	.062	.048	.375
	COV-2111		CO-2111	.343	1.093	.625	.375	.062	.048	.437
	COV-2113		CO-2113	.406	1.156	.750	.437	.062	.048	.500
	COV-2115		CO-2115	.468	1.218	.875	.500	.062	.048	.562
	COV-2117		CO-2117	.531	1.281	1.000	.562	.062	.048	.625

Except for clamping diameter, dimensions of cushioned and plain parts are identical.
 NOTE: Part numbers shown with asterisk (*) are produced from CRCQ Steel, Zinc Plated.

WIRING AND TUBE CLAMPS Closed Type – Furnished Open

MATERIAL: HD Galv Steel, Chem-Treated G90, Per ASTM A653/A653M

CUSHION: Black Vinyl, 1/32" Thick

COV-CO: Parts Have One Round and One Slotted Hole

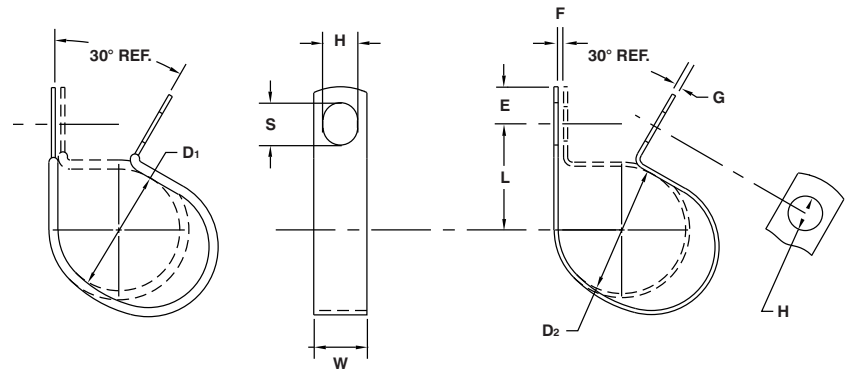

D ₁		D ₂		H	L	W	E	F	G	S
Clamping Diameter	Part Number	Clamping Diameter	Part Number	Hole Diameter	Center To Center	Width	Hole Center To End	Gap	Gage	Slot Length
±.031		±.015		±.005	±.031	±.010	±.015	±.031	See Pg. 40	±.020
1.312	COV-2209	1.375	CO-2209	.281	1.062	.500	.312	.062	.048	.375
	COV-2211		CO-2211	.343	1.125	.625	.375	.062	.048	.437
	COV-2213		CO-2213	.406	1.187	.750	.437	.062	.048	.500
	COV-2215		CO-2215	.468	1.250	.875	.500	.062	.048	.562
	COV-2217		CO-2217	.531	1.312	1.000	.562	.062	.048	.625
1.375	COV-2309	1.437	CO-2309	.281	1.093	.500	.312	.062	.048	.375
	COV-2311		CO-2311	.343	1.156	.625	.375	.062	.048	.437
	COV-2313		CO-2313	.406	1.218	.750	.437	.062	.048	.500
	COV-2315		CO-2315	.468	1.281	.875	.500	.062	.048	.562
	COV-2317		CO-2317	.531	1.343	1.000	.562	.062	.048	.625
1.437	COV-2409	1.500	CO-2409	.281	1.125	.500	.312	.062	.048	.375
	COV-2411		CO-2411	.343	1.187	.625	.375	.062	.048	.437
	COV-2413		CO-2413	.406	1.250	.750	.437	.062	.048	.500
	COV-2415		CO-2415	.468	1.312	.875	.500	.062	.048	.562
	COV-2417		CO-2417	.531	1.375	1.000	.562	.062	.048	.625
1.500	COV-2509	1.562	CO-2509	.281	1.156	.500	.312	.062	.048	.375
	COV-2511		CO-2511	.343	1.218	.625	.375	.062	.048	.437
	COV-2513		CO-2513	.406	1.281	.750	.437	.062	.048	.500
	COV-2515		CO-2515	.468	1.343	.875	.500	.062	.048	.562
	COV-2517		CO-2517	.531	1.406	1.000	.562	.062	.048	.625
1.562	COV-2609	1.625	CO-2609	.281	1.187	.500	.312	.062	.048	.375
	COV-2611		CO-2611	.343	1.250	.625	.375	.062	.048	.437
	COV-2613		CO-2613	.406	1.312	.750	.437	.062	.048	.500
	COV-2615		CO-2615	.468	1.375	.875	.500	.062	.048	.562
	COV-2617		CO-2617	.531	1.437	1.000	.562	.062	.048	.625
1.625	COV-2709	1.687	CO-2709	.281	1.218	.500	.312	.062	.048	.375
	COV-2711		CO-2711	.343	1.281	.625	.375	.062	.048	.437
	COV-2713		CO-2713	.406	1.343	.750	.437	.062	.048	.500
	COV-2715		CO-2715	.468	1.406	.875	.500	.062	.048	.562
	COV-2717		CO-2717	.531	1.468	1.000	.562	.062	.048	.625

Except for clamping diameter, dimensions of cushioned and plain parts are identical.
 NOTE: Part numbers shown with asterisk (*) are produced from CRCQ Steel, Zinc Plated.

WIRING AND TUBE CLAMPS Closed Type – Furnished Open

MATERIAL: HD Galv Steel, Chem-Treated G90, Per ASTM A653/A653M

CUSHION: Black Vinyl, 1/32" Thick

COV-CO: Parts Have One Round and One Slotted Hole

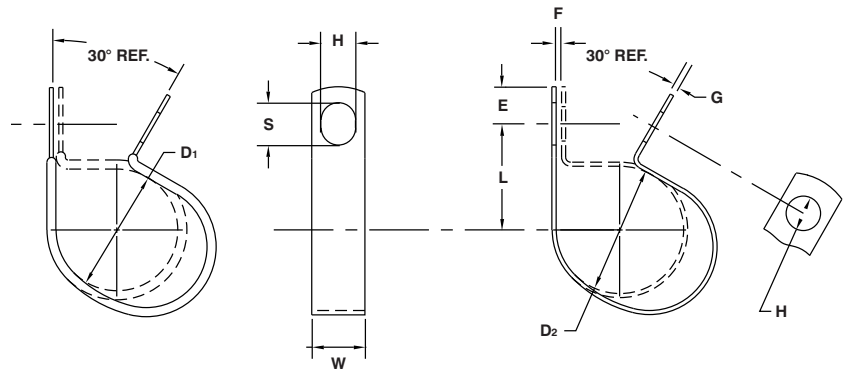

D ₁		D ₂		H	L	W	E	F	G	S
Clamping Diameter	Part Number	Clamping Diameter	Part Number	Hole Diameter	Center To Center	Width	Hole Center To End	Gap	Gage	Slot Length
±.031		±.015		±.005	±.031	±.010	±.015	±.031	See Pg. 40	±.020
1.687	COV-2809	1.750	CO-2809	.281	1.250	.500	.312	.062	.048	.375
	COV-2811		CO-2811	.343	1.312	.625	.375	.062	.048	.437
	COV-2813		CO-2813	.406	1.375	.750	.437	.062	.048	.500
	COV-2815		CO-2815	.468	1.437	.875	.500	.062	.048	.562
	COV-2817		CO-2817	.531	1.500	1.000	.562	.062	.048	.625
1.750	COV-2909	1.812	CO-2909	.281	1.281	.500	.312	.062	.048	.375
	COV-2911		CO-2911	.343	1.343	.625	.375	.062	.048	.437
	COV-2913		CO-2913	.406	1.406	.750	.437	.062	.048	.500
	COV-2915		CO-2915	.468	1.468	.875	.500	.062	.048	.562
	COV-2917		CO-2917	.531	1.531	1.000	.562	.062	.048	.625
1.812	COV-3009	1.875	CO-3009	.281	1.312	.500	.312	.062	.048	.375
	COV-3011		CO-3011	.343	1.375	.625	.375	.062	.048	.437
	COV-3013		CO-3013	.406	1.437	.750	.437	.062	.048	.500
	COV-3015		CO-3015	.468	1.500	.875	.500	.062	.048	.562
	COV-3017		CO-3017	.531	1.562	1.000	.562	.062	.048	.625
1.875	COV-3109	1.937	CO-3109	.281	1.343	.500	.312	.062	.048	.375
	COV-3111		CO-3111	.343	1.406	.625	.375	.062	.048	.437
	COV-3113		CO-3113	.406	1.468	.750	.437	.062	.048	.500
	COV-3115		CO-3115	.468	1.531	.875	.500	.062	.048	.562
	COV-3117		CO-3117	.531	1.593	1.000	.562	.062	.048	.625
1.937	COV-3209	2.000	CO-3209	.281	1.375	.500	.312	.062	.048	.375
	COV-3211		CO-3211	.343	1.437	.625	.375	.062	.048	.437
	COV-3213		CO-3213	.406	1.500	.750	.437	.062	.048	.500
	COV-3215		CO-3215	.468	1.562	.875	.500	.062	.048	.562
	COV-3217		CO-3217	.531	1.625	1.000	.562	.062	.048	.625
2.000	COV-3309	2.062	CO-3309	.281	1.437	.500	.312	.062	.048	.375
	COV-3311		CO-3311	.343	1.500	.625	.375	.062	.048	.437
	COV-3313		CO-3313	.406	1.562	.750	.437	.062	.048	.500
	COV-3315		CO-3315	.468	1.625	.875	.500	.062	.048	.562
	COV-3317		CO-3317	.531	1.687	1.000	.562	.062	.048	.625

Except for clamping diameter, dimensions of cushioned and plain parts are identical.
NOTE: Part numbers shown with asterisk (*) are produced from CRCQ Steel, Zinc Plated.

WIRING AND TUBE CLAMPS Closed Type – Furnished Open

MATERIAL: HD Galv Steel, Chem-Treated G90, Per ASTM A653/A653M

CUSHION: Black Vinyl, 1/32" Thick

COV-CO: Parts Have One Round and One Slotted Hole

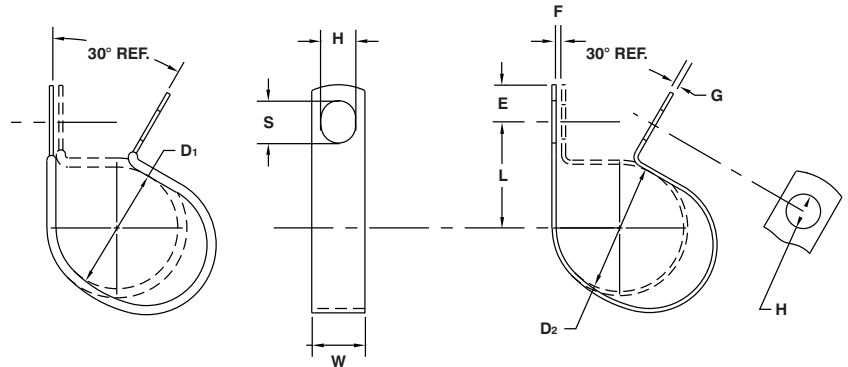

D ₁		D ₂		H	L	W	E	F	G	S
Clamping Diameter	Part Number	Clamping Diameter	Part Number	Hole Diameter	Center To Center	Width	Hole Center To End	Gap	Gage	Slot Length
±.031		±.015		±.005	±.031	±.010	±.015	±.031	See Pg. 40	±.020
2.062	COV-3409	2.125	CO-3409	.281	1.468	.500	.312	.062	.048	.375
	COV-3411		CO-3411	.343	1.531	.625	.375	.062	.048	.437
	COV-3413		CO-3413	.406	1.593	.750	.437	.062	.048	.500
	COV-3415		CO-3415	.468	1.656	.875	.500	.062	.048	.562
	COV-3417		CO-3417	.531	1.718	1.000	.562	.062	.048	.625
2.125	COV-3509	2.187	CO-3509	.281	1.500	.500	.312	.062	.048	.375
	COV-3511		CO-3511	.343	1.562	.625	.375	.062	.048	.437
	COV-3513		CO-3513	.406	1.625	.750	.437	.062	.048	.500
	COV-3515		CO-3515	.468	1.688	.875	.500	.062	.048	.562
	COV-3517		CO-3517	.531	1.750	1.000	.562	.062	.048	.625
2.187	COV-3609	2.250	CO-3609	.281	1.531	.500	.312	.062	.048	.375
	COV-3611		CO-3611	.343	1.593	.625	.375	.062	.048	.437
	COV-3613		CO-3613	.406	1.656	.750	.437	.062	.048	.500
	COV-3615		CO-3615	.468	1.718	.875	.500	.062	.048	.562
	COV-3617		CO-3617	.531	1.781	1.000	.562	.062	.048	.625
2.250	COV-3709	2.312	CO-3709	.281	1.562	.500	.312	.062	.048	.375
	COV-3711		CO-3711	.343	1.625	.625	.375	.062	.048	.437
	COV-3713		CO-3713	.406	1.687	.750	.437	.062	.048	.500
	COV-3715		CO-3715	.468	1.750	.875	.500	.062	.048	.562
	COV-3717		CO-3717	.531	1.812	1.000	.562	.062	.048	.625
2.375	COV-3909	2.437	CO-3909	.281	1.625	.500	.312	.062	.048	.375
	COV-3911		CO-3911	.343	1.687	.625	.375	.062	.048	.437
	COV-3913		CO-3913	.406	1.750	.750	.437	.062	.048	.500
	COV-3915		CO-3915	.468	1.812	.875	.500	.062	.048	.562
	COV-3917		CO-3917	.531	1.875	1.000	.562	.062	.048	.625
2.500	COV-4109	2.562	CO-4109	.281	1.687	.500	.312	.062	.048	.375
	COV-4111		CO-4111	.343	1.750	.625	.375	.062	.048	.437
	COV-4113		CO-4113	.406	1.812	.750	.437	.062	.048	.500
	COV-4115		CO-4115	.468	1.875	.875	.500	.062	.048	.562
	COV-4117		CO-4117	.531	1.937	1.000	.562	.062	.048	.625
2.625	COV-4309	2.687	CO-4309	.281	1.750	.500	.312	.062	.048	.375
	COV-4311		CO-4311	.343	1.812	.625	.375	.062	.048	.437
	COV-4313		CO-4313	.406	1.875	.750	.437	.062	.048	.500
	COV-4315		CO-4315	.468	1.937	.875	.500	.062	.048	.562
	COV-4317		CO-4317	.531	2.000	1.000	.562	.062	.048	.625

Except for clamping diameter, dimensions of cushioned and plain parts are identical.

NOTE: Part numbers shown with asterisk (*) are produced from CRCQ Steel, Zinc Plated.

WIRING AND TUBE CLAMPS Closed Type – Furnished Open

MATERIAL: HD Galv Steel, Chem-Treated G90, Per ASTM A653/A653M

CUSHION: Black Vinyl, 1/32" Thick

COV-CO: Parts Have One Round and One Slotted Hole

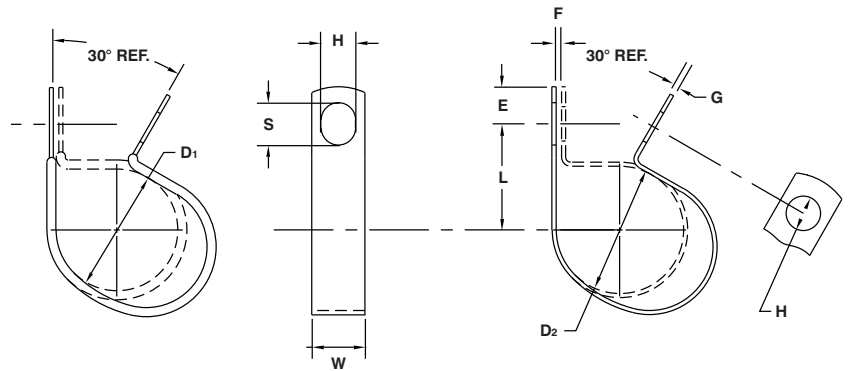

D ₁		D ₂		H	L	W	E	F	G	S
Clamping Diameter	Part Number	Clamping Diameter	Part Number	Hole Diameter	Center To Center	Width	Hole Center To End	Gap	Gage	Slot Length
±.031		±.015		±.005	±.031	±.010	±.015	±.031	See Pg. 40	±.020
2.750	COV-4509	2.812	CO-4509	.281	1.812	.500	.312	.062	.048	.375
	COV-4511		CO-4511	.343	1.875	.625	.375	.062	.048	.437
	COV-4513		CO-4513	.406	1.937	.750	.437	.062	.048	.500
	COV-4515		CO-4515	.468	2.000	.875	.500	.062	.048	.562
	COV-4517		CO-4517	.531	2.062	1.000	.562	.062	.048	.625
2.875	COV-4709	2.937	CO-4709	.281	1.875	.500	.312	.062	.048	.375
	COV-4711		CO-4711	.343	1.937	.625	.375	.062	.048	.437
	COV-4713		CO-4713	.406	2.000	.750	.437	.062	.048	.500
	COV-4715		CO-4715	.468	2.062	.875	.500	.062	.048	.562
	COV-4717		CO-4717	.531	2.125	1.000	.562	.062	.048	.625
3.000	COV-4909	3.062	CO-4909	.281	1.937	.500	.312	.062	.048	.375
	COV-4911		CO-4911	.343	2.000	.625	.375	.062	.048	.437
	COV-4913		CO-4913	.406	2.062	.750	.437	.062	.048	.500
	COV-4915		CO-4915	.468	2.125	.875	.500	.062	.048	.562
	COV-4917		CO-4917	.531	2.187	1.000	.562	.062	.048	.625
3.250	COV-5309	3.312	CO-5309	.281	2.062	.500	.312	.062	.048	.375
	COV-5311		CO-5311	.343	2.125	.625	.375	.062	.048	.437
	COV-5313		CO-5313	.406	2.187	.750	.437	.062	.048	.500
	COV-5315		CO-5315	.468	2.250	.875	.500	.062	.048	.562
	COV-5317		CO-5317	.531	2.312	1.000	.562	.062	.048	.625
3.500	COV-5709	3.562	CO-5709	.281	2.187	.500	.312	.062	.048	.375
	COV-5711		CO-5711	.343	2.250	.625	.375	.062	.048	.437
	COV-5713		CO-5713	.406	2.312	.750	.437	.062	.048	.500
	COV-5715		CO-5715	.468	2.375	.875	.500	.062	.048	.562
	COV-5717		CO-5717	.531	2.437	1.000	.562	.062	.048	.625
3.750	COV-6109	3.812	CO-6109	.281	2.312	.500	.312	.062	.048	.375
	COV-6111		CO-6111	.343	2.375	.625	.375	.062	.048	.437
	COV-6113		CO-6113	.406	2.437	.750	.437	.062	.048	.500
	COV-6115		CO-6115	.468	2.500	.875	.500	.062	.048	.562
	COV-6117		CO-6117	.531	2.562	1.000	.562	.062	.048	.625
4.000	COV-6509	4.062	CO-6509	.281	2.437	.500	.312	.062	.048	.375
	COV-6511		CO-6511	.343	2.500	.625	.375	.062	.048	.437
	COV-6513		CO-6513	.406	2.562	.750	.437	.062	.048	.500
	COV-6515		CO-6515	.468	2.625	.875	.500	.062	.048	.562
	COV-6517		CO-6517	.531	2.687	1.000	.562	.062	.048	.625

Except for clamping diameter, dimensions of cushioned and plain parts are identical.

NOTE: Part numbers shown with asterisk (*) are produced from CRCQ Steel, Zinc Plated.